

# HONEYWELL HERMETIC UTIMETER GTEX N SERIES

The leading portable gauging unit for marine applications

Honeywell

# CONTENTS

## PAGE

# INTRODUCTION TO HERMETIC UTIMETERS

Honeywell HERMetic UTImeters are important intrinsically safe portable electronic level gauging equipments designed for accurate inventory control, cargo inspection during custody transfer and verification or calibration of automatic gauging system.

HERMetic UTImeters offer gas-tight or closed type portable gauging of hydrocarbon and chemical inside Zone 0 classified tanks, operating in a closed system that do not permit the direct exposure and/or release of any tank contents to the atmosphere. The manual closed gauging measurements are done via vapour lock valve, using closed type HERMetic UTImeters that provides a safe gas-tight seal for the operator taking readings.

This avoids pressure loss in tanks forming a part of vapour balancing / recovery systems and minimizes environmental impact from exposure to potential hazardous vapours contained in VOCs (Volatile Organic Compounds). A closed system exists when a marine tank vessel does not permit the direct exposure and/or release of the tank content into the atmosphere under normal operating conditions. (API MPMS 17.2 A.4.1.)



# WHAT IS A HERMETIC ULLIMETER GTEX N SERIES?

HERMetic Ullimeter GTEX N series is a portable electronic gauging equipment designed for multi-parameter measurement of ullage, temperature, oil-water interface and innage (reference height) of stored hydrocarbons and chemicals in various storage tanks on ships.

The reading seen at the tape window coincides with the zero ullage readout point of the tank. For ensuring operator safety, the HERMetic Ullimeter GTEX N Series is only connected to HERMetic vapour control valve permanently fixed on the tank. The light weight and battery-operated design ensures anytime availability of measurement point at any tank locations equipped with a vapour control valve.

## PRINCIPLE OF INSTALLATION

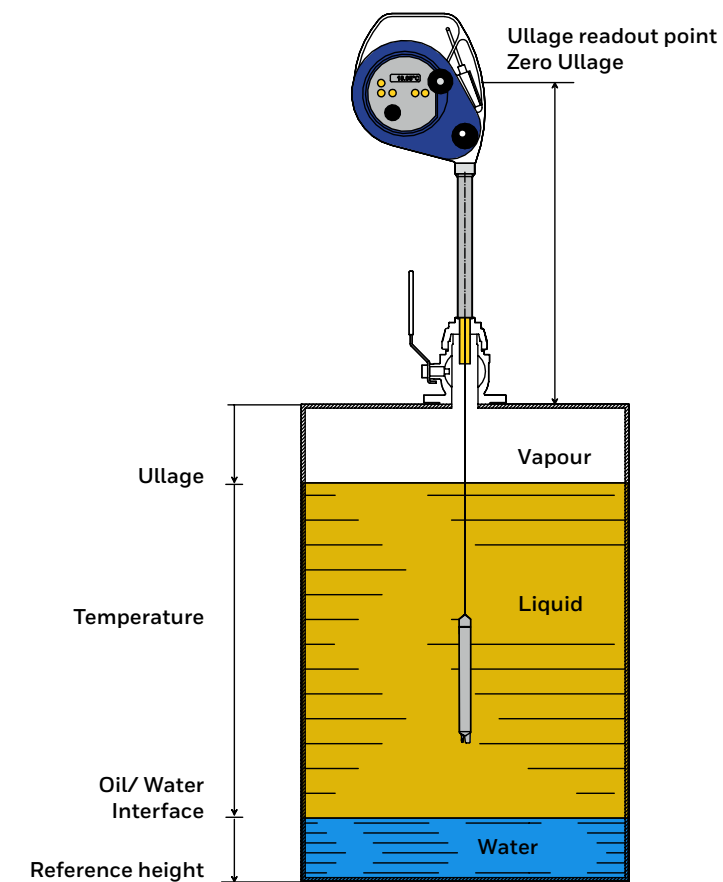

# HOW HERMETIC UTIMETER GTEX N SERIES SOLVES OPERATIONAL CHALLENGES?

For commercial success of cargo tanker operations, the HERMetic UTImeter GTEX N series is the best business-friendly investment which tackles many issues like:

## PROBLEM

### Slow sensor response

Many portable gauges have sensors giving slow response after touching top media surface. This time gap results in tape moving deeper into media resulting in lower measured level – leading to inaccurate readings.

## SOLUTION

HERMetic UTImeter GTEX series offers fast sensor response immediately on touching top media surface.

## PROBLEM

### Loss of sensor sensitivity

The sensitivity for ullage and interface measurement degrades over time in sensors of many portable gauges. This leads to higher response time gap resulting in inaccurate reading. To correct this issue, sensor needs to be serviced for calibration, adjustment, or replacement.

## SOLUTION

The ULTRA sensor in HERMetic UTImeter GTEX **does not require any calibration or adjustment of sensitivity.**

## PROBLEM

### Temperature calibration during change of sensor

With frequent use of portable gauges in extreme conditions, replacement of sensor is essential to achieve top performance. Many portable gauges require sensor to be calibrated after replacement to achieve accurate temperature measurement.

## SOLUTION

The built-in temperature transducer characteristics of ULTRA sensor ensure HERMetic UTImeter N series electronics displays true temperature values.

## PROBLEM

### Frequent tape damage when closing valves

The crew on ships are changing frequently every 6 to 9 months. An operator unfamiliar with the equipment could accidentally close the valve while the portable gauge tape and sensor are still inside the tank – resulting in damage of tape requiring spare part replacement.

## SOLUTION

The HERMetic UTImeter N series is equipped with a special tape protection tube to protect the tape from getting cut during accidental closure of valve while sensor is inside the tank. This mechanical safety device prevents damages to tape and reduces repair costs.



# HERMETIC UTIMETER GTEX N SERIES STRUCTURE AND FUNCTION

HERMetic UTImeter GTEX N series is a portable electronic gauging equipment designed for multi-parameter measurement of ullage, temperature, oil-water interface and innage (reference height) of stored hydrocarbons and chemicals in various storage tanks on ships.

HERMetic UTImeters are operated by fitting the portable gauge on a vapour lock valve, followed by opening of the valve and clockwise winding of the tape and sensor assembly till alarm is heard on the buzzer. The level reading is taken from the graduated tape seen through the tape window.

After reading is recorded, unwinding of tape and sensor assembly is done till the sensor is retracted completely into the portable gauge and the valve can be fully closed without any obstruction.

While sensor moves through air medium of tank, alarm beeps periodically after every 2 seconds, when sensor touches oil medium, the alarm beeps continuously and when the sensor touches the water medium of oil-water interface, alarm beeps periodically every 0.5 second.



Level reading on graduated tape through window



Easy access to the tape allows fast cleaning. No screws, only five easy to open lid fastener

Tape cleaning device

Tape protection tube



## TAPE LENGTH VERSIONS

The HERMetric UTImeter GTEX N series is available with following tape length versions across the various models.

MODEL	15M	25M	35M	50M	55M	60M
TS NGUTI	✓	✓	✓			
TS NHUTI		✓				
TS NLUTI				✓		
TS NXUTI					✓	✓

## GAS GROUP VERSIONS

The HERMetric UTImeter GTEX N series is available with following gas group approval linked with the application.

VERSION	APPLICATION
Standard	For use with non-corrosive liquids
Chemical IIB	For use with non-corrosive and corrosive liquids
Chemical IIC	For use with non-corrosive and highly corrosive liquids

## STORAGE TUBE VERSIONS

The HERMetric UTImeter GTEX N series is fitted with storage tubes of 3 different sizes. The storage tube houses the ULTRA sensors when the tapes are fully retracted.

**Storage tube SS1-Q2**



**Storage tube SS1-Q1**



**Storage tube SS2-Q2  
For Visc Version**



Sensor fitted with additional load, recommended for operation in high viscous products or for innage measurements

## TAPE CLEANING FUNCTION

The complete HERMetric UTImeter GTEX N series versions are equipped with a mechanical tape cleaning device which is easy to engage using a dedicated knob on the front side. This in-line tape cleaning feature helps achieve clean retraction of tape free from oil or chemical.



**Tape cleaner open or disengaged when lowering sensor**



**Tape cleaner closed or engaged when rewinding sensor**



## SPECIAL STORAGE TUBES FOR NON-HERMETIC VALVES

We have designed special storage tubes for connecting HERMetric UTImeter N series equipment's to an existing non-HERMetric valve available on board the ship. Honeywell can deliver most of its gauges with the suitable custom storage tube which will retain zero reference at the correct position.



A grounding cable has to be installed if HERMetric gauges are used with non-HERMetric valves.

## PACKAGING

All HERMetric portable level gauges are delivered with a tailor-made plywood carrying case as a standard. This special box avoids any damage during transport and storage.



## TECHNICAL SPECIFICATIONS

Accuracy of ullage-interface detection	± 2 mm (± 0.08" approx.)
Ullage, interface indication	Audible and Visible selectable
Maximum tank overpressure	0,3 bar (4,4 psi)
Tape length	15 m/50 ft, 25 m/82 ft, 35 m/115 ft
Tape graduation	Metric/English
Tape resolution	1 mm / 1/16"
Tape accuracy	± 1.5 mm/30 m (±1/16"/100 ft approx.)
Meets API MPMS Chap 3.1A and ISO 4512 requirements	
Temperature accuracy	± 0.1°C (0°C to 70°C);
Meets API MPMS Chap 7 request ± 0.2°F (32°F to 158°F)	
Meets ISO 4268 , IP PMM Part IV	
Ambient temperature range	-20°C to 50°C / (-4°F to 122°F)
Temperature sensor measurement range	-40°C to 90°C / (-40°F to 194°F)
Temperature measurement resolution	0.01° or 0.1° selectable
Temperature reading	°C or °F selectable
LCD Display	8 characters with backlight
Power	Approved 9V batteries
Weight with 15 meter / 50ft tape	4.4 kg / 9.7 Lbs.
Hazardous environments approvals	
ATEX	II 1 G Ex ia IIC T4 Ga / -20°C ≤ Ta ≤ +50°C / -40°C ≤ Tp ≤ +90°C
IECEX	Ex ia IIC T4 Ga / -20°C < Ta < +50°C / -40°C ≤ Tp ≤ +90°C
FM Approvals	CL I, DIV 1, GP A, B, C&D, T4 Tamb 50°C and CL I, ZN 0, AEx ia IIC T4 Tamb 50°C Maximum Process Temp +90°C

## VAPOUR LOCK VALVES

The HERMetic Compact valves are specially designed to fit all portable HERMetic equipment with a HERMetic quick connector and represent the base for the zero-ullage reference when installed at the appropriate height. They ensure a safe and reliable operation of all portable HERMetic units certified for use in classified areas. The valves are available in three different sizes: 1 Inch, 2 Inch and 4 Inch. HERMetic valves are approved by all major classification societies.

### 1 INCH HERMETIC VALVE SERIES



**C1-SS-W**

#### HERMETIC COMPACT VALVE C1-SS-W

1 Inch full bore ball valve with 1 Inch male BSP pipe thread designed to support all portable HERMetic equipment with HERMetic 1 Inch quick connector.



**C1-SS-P**

#### HERMETIC COMPACT VALVE C1-SS-P

1 Inch valve fitted with a special pressure cap cover. This cover is specially designed for use with hazardous chemicals and protect against inadvertent opening.

## 2 INCH HERMETIC VALVE SERIES

### HERMETIC COMPACT VALVE C2-SS-BL

2 Inch full bore ball valve made of corrosion resistant stainless steel with high Molybdenum content. The top part is designed to support HERMetic equipment with 2 Inch quick connector. The bottom section has a DUJ multistandard flange or G2" Whitworth Parallel Pipe Thread DIN ISO 228 / DIN 259 BSPP (British Standard Pipe Parallel) female threaded connection.



**C2-SS-BL**



**C2-SS-BL Female**

\*Option: Special handle for pad lock.

Weight: 4,8 kg

### HERMETIC COMPACT VALVE C2-SS-W

Same valve as HERMetic Compact valve C2-SS-BL except the cover, which is fitted with a 1 Inch quick-connect nipple identical to the one supplied on the smaller C1-SS-W Compact valve. This nipple matches with all HERMetic units and accessories with 1 Inch connection. The complete cover can be removed for connection of equipment with 2 Inch connector.



**C2-SS-W**



**C2-SS-W Female**

\*Option: Special handle for pad lock.

Weight: 5,1 kg

Materials: Stainless steel AISI 316, PTFE seats

### HERMETIC COMPACT VALVE C2-SS-SEC

Same valve as HERMetic Compact valve C2-SS-BL except a doubly locked security cover which prevents any water ingress and protects against inadvertent opening. The cover is secured to the valve with a stainless-steel cable. Specially designed for hazardous chemicals.



**C2-SS-SEC**

**C2-SS-SEC Female**

\*Option: Special handle for pad lock.

Weight: 5,4 kg

Materials: Stainless steel AISI 316, PTFE seats

All HERMetic 2 Inch ball valve are available with 2 Inch female thread or with DUJ multistandard flange.

DUJ multistandard flange fits following standards:

DIN PN 10 DN 50

DIN PN 25 DN 50

DIN PN 16 DN 50

DIN PN 40 DN 50

JIS 5K 50

JIS 10K 50

ANSI 150 lbs 2 Inch

**Materials:** Stainless steel AISI 316 with minimal Mo content 2.7%, PTFE seats

## 4 INCH HERMETIC VALVE SERIES



**C1-SS-W**

### HERMETIC COMPACT VALVE A-4 SS

Specially designed heavy-duty compact ball valve totally made of stainless steel 316 and with Teflon gaskets. The deck flange is according to ANSI 150 lbs. standard. This 4 Inch deck valve is provided with a swing away cover fitted with a 1 Inch quick-connect male coupling. This coupling takes all HERMETic equipment fitted with a 1 Inch female quick connector. For sampling, open the cover and install the HERMETic Sampler A-4 or Sampler GT4 on top of the valve. Three wing nuts are used to secure the cover or alternatively the sampler chamber.

Weight: 24 kg

Materials: Stainless steel AISI 316, PTFE seats

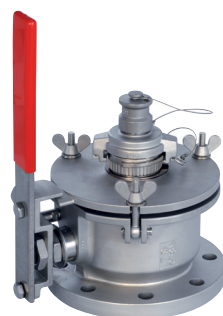

**C1-SS-P**

### HERMETIC COMPACT VALVE A-4-2-1 SS

This valve has been specifically designed so that all the HERMETic equipment, with either 1", 2", or 4" connections, will be compatible. Organisations such as the American Petroleum Institute and the Energy Institute, recommend the size of the vapour valve to be 4" (100mm). The 4" valve will allow access to a larger number of gauging and sampling equipment than ever before, depending on the product and sample type required. Vapour valves smaller than 100mm in diameter are suitable for gauging but can severely limit the type of sampling equipment that can be used and, ultimately, the quality of the sample. The size and location of the vapour valve for closed system measurement and sampling is critical to the process. A valve of the proper size, located correctly, will allow more accurate measurements to be taken than one that is improperly located and of insufficient size. The new multi-purpose valve gives the flexibility to gauge products from crude to chemicals. Most importantly, it will allow the use of sampling equipment with the capabilities of retrieving sample quantities from 0.33 litres to 1.8 litres in one single operation.

Weight: 25 kg

Materials: Stainless steel AISI 316, PTFE seats

## VALVE OPERATION

During open-close operation of the valve, the sensor along with the tape protection tube exits the storage tube for the 1 Inch and 2 Inch valves as shown in below sketch.

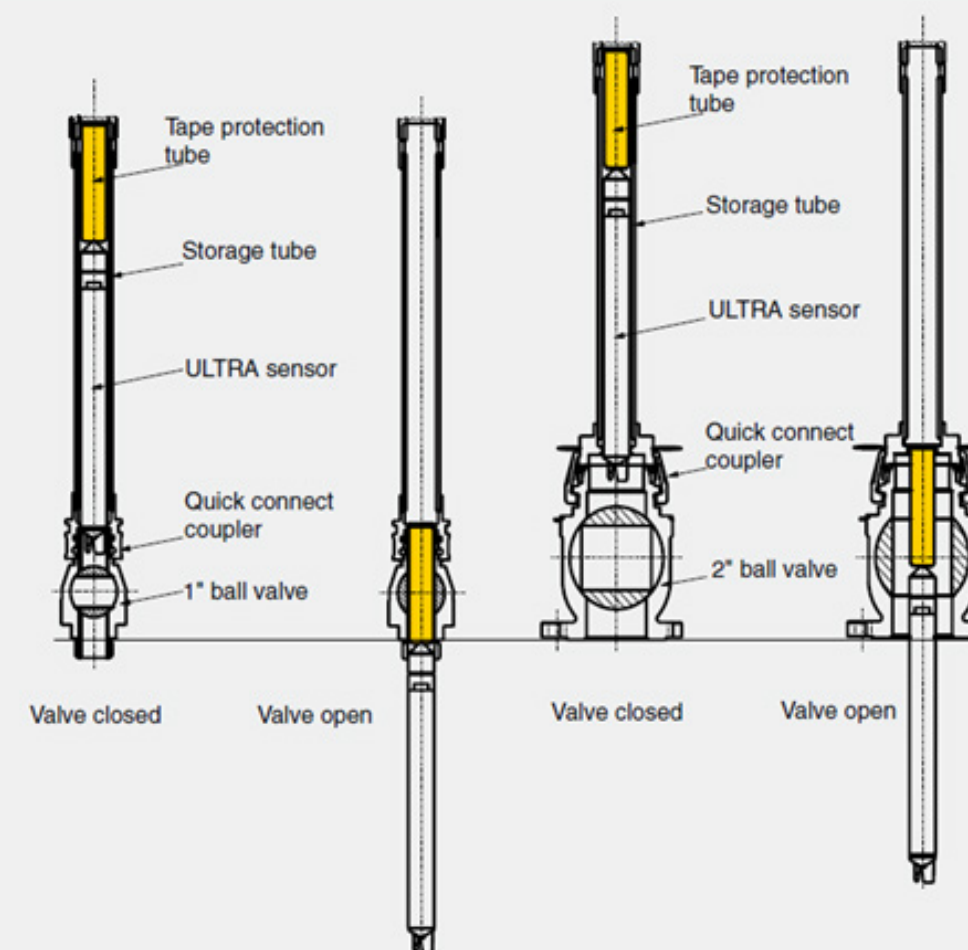

# MODEL SELECTION CRITERIA FOR HERMETIC UTIMETERS & VALVES

We have a wide range of HERMetric UTImeters suited for portable gauging under various usage conditions and requirements



MODEL	LIQUID TYPE	TAPE LENGTH	EX CLASS TYPE	CONNECTION SIZES	MAX. TANK PRESSURE
TS NGUTI HERMetric UTImeter Gtex N Series Standard Version For Closed / Gas Tight gauging	<ul style="list-style-type: none"> <li>• Crude Oil &amp; Petroleum Products</li> <li>• Light Chemicals</li> </ul>	<ul style="list-style-type: none"> <li>• 15 m / 50 ft</li> <li>• 25 m / 82 ft</li> <li>• 35 m / 115 ft</li> </ul>	IIB	<ul style="list-style-type: none"> <li>• 1 Inch</li> <li>• 2 Inch</li> <li>• Special Storage tubes for non-HERMetric valves</li> </ul>	0.3 Bar
TS NGUTI HERMetric UTImeter Gtex N Series Chemical Version IIC	<ul style="list-style-type: none"> <li>• Chemicals</li> </ul>	<ul style="list-style-type: none"> <li>• 15 m / 50 ft</li> <li>• 25 m / 82 ft</li> </ul>	IIC	<ul style="list-style-type: none"> <li>• 1 Inch</li> <li>• 2 Inch</li> <li>• Special Storage tubes for non-HERMetric valves</li> </ul>	0.3 Bar
TS NHUTI HERMetric UTImeter Gtex N Series High Pressure Version	<ul style="list-style-type: none"> <li>• Crude Oil &amp; Petroleum Products</li> <li>• Light Chemicals</li> </ul>	<ul style="list-style-type: none"> <li>• 25 m / 82 ft</li> </ul>	IIB	<ul style="list-style-type: none"> <li>• 1 Inch</li> <li>• 2 Inch</li> <li>• Special Storage tubes for non-HERMetric valves</li> </ul>	0.7 Bar



MODEL	LIQUID TYPE	TAPE LENGTH	EX CLASS TYPE	CONNECTION SIZES	MAX. TANK PRESSURE
TS NLUTI HERMetric UTImeter Gtex N Series Long Range Version	<ul style="list-style-type: none"> <li>• Crude Oil &amp; Petroleum Products</li> <li>• Light Chemicals</li> </ul>	<ul style="list-style-type: none"> <li>• 50 m / 164 ft</li> </ul>	IIB	<ul style="list-style-type: none"> <li>• 1 Inch</li> <li>• 2 Inch</li> <li>• Special Storage tubes for non-HERMetric valves</li> </ul>	0.3 Bar
TS NXUTI HERMetric UTImeter Gtex N Series Extra Long Range Version	<ul style="list-style-type: none"> <li>• Crude Oil &amp; Petroleum Products</li> <li>• Light Chemicals</li> </ul>	<ul style="list-style-type: none"> <li>• 55 m / 180 ft</li> <li>• 60 m / 196 ft</li> </ul>	IIB	<ul style="list-style-type: none"> <li>• 1 Inch</li> <li>• 2 Inch</li> <li>• Special Storage tubes for non-HERMetric valves</li> </ul>	0.3 Bar
TS NHUTI HERMetric UTImeter Gtex N Series High Pressure Chemical Version IIC	<ul style="list-style-type: none"> <li>• Chemicals</li> </ul>	<ul style="list-style-type: none"> <li>• 25 m / 82 ft</li> </ul>	IIC	<ul style="list-style-type: none"> <li>• 1 Inch</li> <li>• 2 Inch</li> <li>• Special Storage tubes for non-HERMetric valves</li> </ul>	0.7 Bar
TS NRUTI HERMetric UTImeter Rtex N Series Standard Version – For Open / Restricted Gauging Only	<ul style="list-style-type: none"> <li>• Crude Oil &amp; Petroleum Products</li> <li>• Light Chemicals</li> </ul>	<ul style="list-style-type: none"> <li>• 15 m / 50 ft</li> <li>• 25 m / 82 ft</li> <li>• 35 m / 115 ft</li> </ul>	IIB	<ul style="list-style-type: none"> <li>• 1 Inch</li> <li>• 2 Inch</li> <li>• Special Storage tubes for non-HERMetric valves</li> </ul>	0.3 Bar



Following table helps select the right model of HERMetric UTImeter suitable for the liquid media in your storage tanks.

LIQUID MEDIA	TS NGUTI STANDARD	TS NGUTI CHEM IIB	TS NGUTI CHEM IIC
Acetone	No	Yes	Yes
Aniline / Ta	Yes	Yes	Yes
Astm Fuel N° A	Yes	Yes	Yes
Astm Fuel N° B	Yes	Yes	Yes
Astm Fuel N° C	Yes	Yes	Yes
Astm Fuel N° D	Yes	Yes	Yes
Astm Oil N° 1	Yes	Yes	Yes
Astm Oil N° 2	Yes	Yes	Yes
Astm Oil N° 4	Yes	Yes	Yes
Benzaldehyde	No	Yes	Yes
Chlorobenzene (Mono,Di,Tri)	Yes	Yes	Yes
Cresol M	No	No	No
Crude Oil (Non Asphalt Base)	Yes	Yes	Yes
Cyclohexanone	Yes	Yes	Yes
Dichlorethane / Ta	Yes	Yes	Yes
Dichlorobenzene	Yes	Yes	Yes
Ethanol	Yes	Yes	Yes
Ethylglycol	Yes	Yes	Yes
Gazoline Leaded	Yes	Yes	Yes
Gazoline Unleaded	Yes	Yes	Yes
Jet Fuel	Yes	Yes	Yes
JP-4 Aviation Turbine Fuel	Yes	Yes	Yes
JP-5 Aviation Turbine Fuel	Yes	Yes	Yes
Methylenechloride	Yes	Yes	Yes
Methylethylketone	No	Yes	Yes
Nafta	Yes	Yes	Yes
Nitrobenzene / Ta	Yes	Yes	Yes
Phenol / Ta	No	Yes	Yes
Phosphoric Acid	Yes	Yes	Yes
Pure Mtbe	No	Yes	Yes
Pyridine	No	Yes	Yes
Sulphuric Acid <40°C	Yes	Yes	Yes
Sulphuric Acid >40°C	No	No	No
Toluene	Yes	Yes	Yes
Triclorthylene	Yes	Yes	Yes

### CAUTION NOTICE

The compatibility information in the table has been supplied from reputable sources and must be used ONLY as an equipment selection guide for compatible chemicals. Test the equipment with the chemicals under specific conditions of your application before use. The accuracy, completeness and suitability of above information should be verified. Variations in chemical behaviour due to unknown or unforeseen factors may cause equipment to fail.



# TYPICAL ARRANGEMENT OF VALVES

For optimum gauging and sampling performance, the valves are positioned as shown below for different ship types.

## VLCC, crude oil or oil/chemical tanker

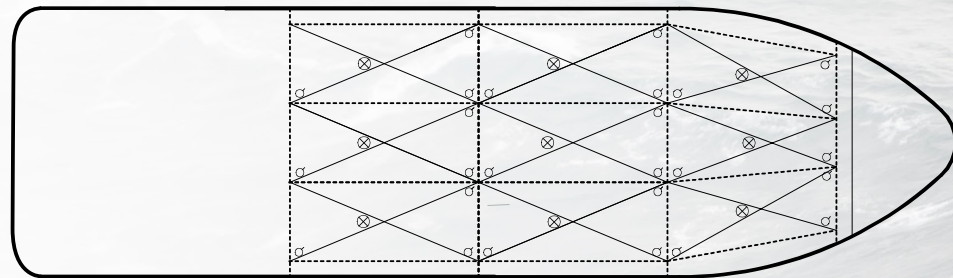

○ 1 Inch ball valves for dipping    ⊗ 2 Inch ball valves for gauging and sampling access

## Product or chemical tanker

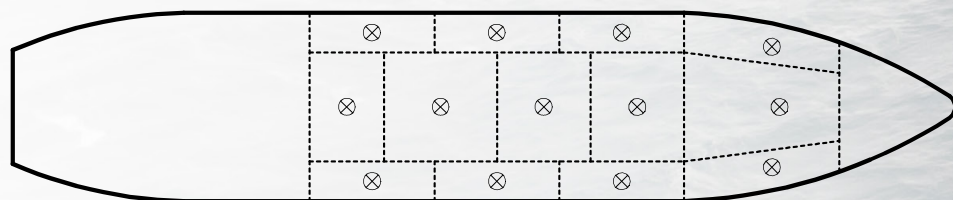

⊗ 2 Inch ball valves for gauging and sampling access



# OTHER PORTABLE GAUGING PRODUCTS AND ACCESSORIES

The following portable gauging products and accessories complement the use of HERMetric UTImeter N Series with additional capabilities, utilizing the same vapour lock valves.

## HERMETIC SAMPLER GTN CHEM



### WHAT DOES IT DO?

Portable gas-tight sampler for liquid sampling with closed liquid transfer for corrosive & non-corrosive liquids.

Installation on HERMetric valves only.

[KNOW MORE](#)

## HERMETIC OXY



### WHAT DOES IT DO?

The HERMetric Oxy is a gas-tight sampler for sampling inert gas or any other gas over height of tank.

Installation on HERMetric valves only.

[KNOW MORE](#)

## HERMETIC SAMPLER GT & GT CHEM



### WHAT DOES IT DO?

Portable gas-tight sampler for liquid sampling with liquid transfer for corrosive & non-corrosive liquids.

Installation on all kinds of valves with special adapters.

[KNOW MORE](#)

## HERMETIC SAMPLER GT4



### WHAT DOES IT DO?

Portable gas-tight sampler for large volume liquid sampling with closed liquid transfer for corrosive & non-corrosive liquids.

Installation on HERMetric valves only.

[KNOW MORE](#)

## HERMETIC PRESS



### WHAT DOES IT DO?

Portable gas-tight pressure gauge for manually checking tank pressure.

Installation on HERMetric valves only.

[KNOW MORE](#)

## HERMETIC SAMPLER GTX CHEM



### WHAT DOES IT DO?

Portable gas-tight sampler for liquid sampling with liquid transfer for corrosive & non-corrosive liquids.

Installation on HERMetric valves only.

[KNOW MORE](#)

## HERMETIC DIP2 GT



### WHAT DOES IT DO?

Portable gas-tight dipping rod assembly for carrying out manual dipping based measurements.

Installation on HERMetric valves only.

[KNOW MORE](#)

# THE FUTURE IS WHAT WE MAKE IT.

The HERMetic UTImeter Gtex N series will be the perfect electronic portable gauge for long term use on ship backed by excellent service support from our Honeywell authorized service stations who are always nearby a port.

The HERMetic UTImeter series products have gained popularity in the portable gauging market since last 30 years with a rich installed base of 10,000 units operated daily on ships. The design has been perfected based on many customer feedbacks received over the past years for use in the most difficult environment.

Enraf Tanksystem SA

ZA La Pièce 16, 1180 Rolle  
Switzerland  
+41 21 695 30 10

[tanksystem@honeywell.com](mailto:tanksystem@honeywell.com)

For More Information  
[www.process.honeywell.com](http://www.process.honeywell.com)

Copyright © 2024 Honeywell International Inc.

**Honeywell**