

# OXY-THERM<sup>®</sup> FHR

Dual-Fuel Oxygen Burners



Be prepared for tomorrow's tighter emissions standards. The next generation in oxy-fuel technology, the OXY-THERM FHR burner uses patented staged oxygen design to provide improved radiant heat transfer in glass furnaces while significantly reducing NO<sub>x</sub> emissions and improving operational flexibility.



## PERFORMANCE BENEFITS

- Patented fuel nozzle design provides high aspect ratio flat flame for greater furnace coverage
- US Patent Number 9,851,099 - For Flat Fuel Nozzle Design
- Firing range of 0.5 – 24 MBtu/h
- Fuel savings of as much as 25% (gas) or 40% (oil) compared to air-fuel burners
- Produces the lowest NO<sub>x</sub> emissions in the industry

## OPERATIONAL FLEXIBILITY

- Four block sizes, custom gas and oil nozzles sized for each burner location
- Capable of firing an up to 20% Hydrogen/80% Natural Gas fuel blend
- Dual fuel capable: simply change the nozzle to change the fuel
- Change fuel type or burner capacity without replacing the housing assembly
- Adjustable oxygen staging to vary flame length, heat flux profile and radiant heat transfer
- US Patent Number 9,939,151 - For Staged Oxygen Design

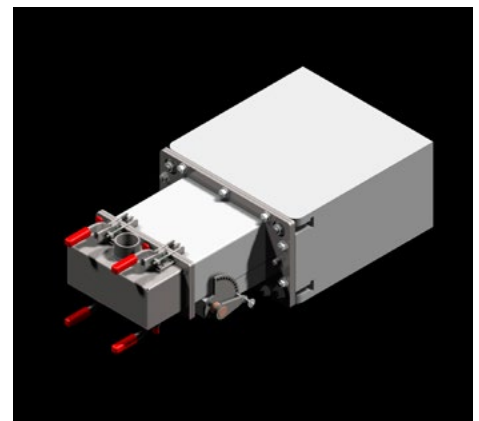

**Honeywell**

OXY- THERM FHR GAS/OIL		S	M	L	XL
Maximum capacity range	MBtu/h	0.5 - 3.2	2.9-6.3	6.0-13.1	10.0-24.0
	MW	0.15-0.94	0.85-1.8	1.7-3.8	2.9-7.0

## APPLICATIONS

OXYTHERM® FHR burners reduce fuel consumption in high temperature (>1400°F) applications. The higher flame temperature of oxy-fuel firing increases the available heat and radiant heat transfer to most applications. Typical improvements include increased thermal efficiency, increased processing rates, higher product quality, reduced flue gas volumes and reduced pollutant emissions.

OXYTHERM® burners have been successfully applied to glass furnaces, day tanks, incinerators, metal melting furnaces, linear and rotary hearth furnaces, reheat furnaces, kilns, and many other types of high temperature (>1400°F) applications.



### For More Information

The Honeywell Thermal Solutions family of products includes Honeywell Combustion Controls, Honeywell Combustion Safety, Honeywell Combustion Service, Eclipse, Exothermics, Hauck, Kromschroder and Maxon. To learn more about our products, visit [ThermalSolutions.Honeywell.com](http://ThermalSolutions.Honeywell.com) or contact your Honeywell Sales Engineer.

### Honeywell Process Solutions

1250 West Sam Houston Parkway South Houston,  
TX 77042

Honeywell House, Arlington Business Park  
Bracknell, Berkshire, England RG12 1EB UK

Shanghai City Centre, 100 Zunyi  
Road Shanghai, China 200051