

# PMC-GAS-ELSTER

## SEMINARS 2025

Expert knowledge for the application, commissioning  
and maintenance of the devices

---

English

---

A large industrial refinery or chemical plant at night, illuminated by numerous lights. The scene features several tall distillation columns and complex piping systems. The sky is a deep blue, suggesting dusk or dawn. The overall atmosphere is industrial and brightly lit against the dark background.

**Honeywell**



## CONTENT

WELCOME TO OUR SEMINARS.....	3
INDUSTRIAL GAS METERING.....	4
BASICS OF VOLUME CONVERSION AND EVC EK280/EK205.....	5
USM 1 .....	6
USM 2 (EXPERIENCED USERS) .....	7
MEASUREMENT-IQ FOR GAS .....	8
INDUSTRIAL GAS FLOW COMPUTER ENCORE FC1 .....	9
GAS QUALITY ANALYZER ENCAL3000.....	10
GAS QUALITY ANALYZER ENCAL PROCHAIN .....	11
GASLAB Q2 SEMINAR .....	12
ON-SITE SEMINARS.....	13
HOW TO FIND US.....	14
REGISTRATION & ORGANIZATION .....	15



**Editorial**

## **WELCOME TO OUR SEMINARS**

Dear Customers,

the future development of the climate and energy supplies is of great concern to all of us and we read new headlines on these topics every day.

What will our mobility look like in the future?

How will we heat our homes and houses?

Will we still be able to book flights as we do it today?

The use of natural gas is part of our current energy mix, and the transport and distribution of gaseous energy sources will continue to be a task in energy supply well into the future.  
Let us make our contribution to a successful transformation.

This Elster Gas products seminar brochure for 2025 contains all our specialist courses to keep your personnel up to date with all the latest developments. Whether you prefer a seminar in Mainz-Kastel, Dortmund or at your premises, we will try find the perfect solution for your training requirements. Just get in touch.

Yours sincerely,  
Paul Schamari  
Seminar Manager Mainz-Kastel

Contact:  
T: +49 61 34 605 299  
paul.schamari@honeywell.com



Which meter for which system?

**TRAINING ON REQUEST**

## INDUSTRIAL GAS METERING

### AIM

In this 2-day seminar participants learn the basics of device functions and the calibration requirements for gas meter, volume converter and process gas chromatograph applications. This is important knowledge for the selection, installation and use of the devices



### CONTENTS

- Fundamentals of gas metering and the metering chain
- Aspects of the testing agency
- Design of meters, volume conversion devices, rotary and turbine gas meters
- Gas meter/volume converter system
- Expert discussion about rotary and turbine gas meters and volume conversion devices
- Remote data transfer from volume conversion devices



### TARGET GROUP

Grid Planners, engineers, officers, field service personnel, in general all people interested gas metering.

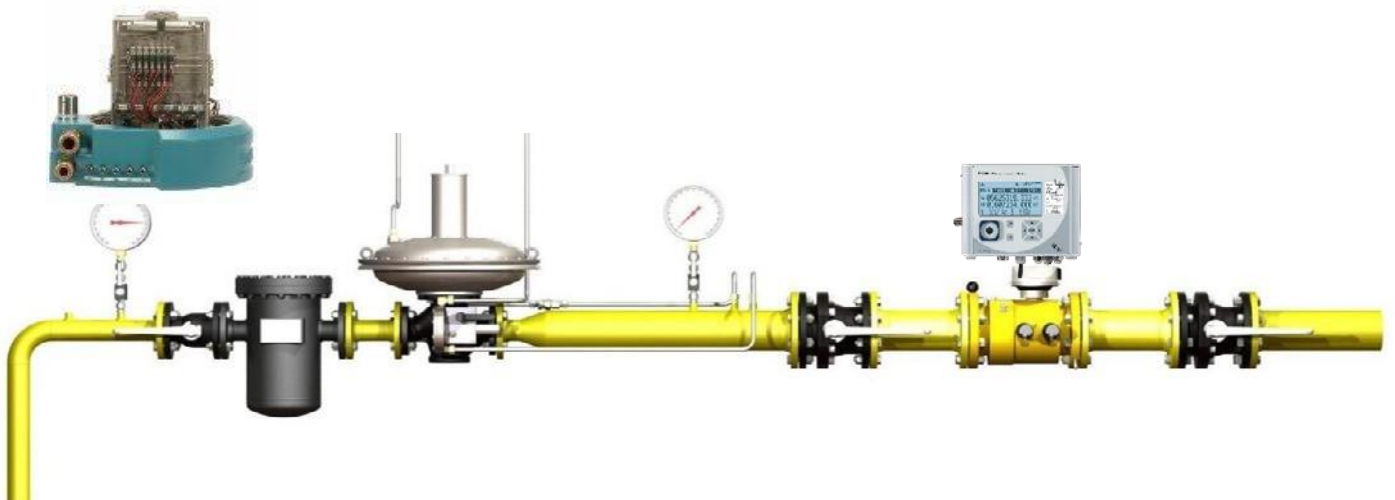



Basics of Volume Conversion and compact Volume Converter applications

**TRAINING ON REQUEST**

## BASICS OF VOLUME CONVERSION AND EVC EK280/EK205

### AIM

In this 2-day seminar, participants learn the basics of volume conversion and the basic handling of the main functions of compact Volume Conversion Devices EK280 and/or EK205. Parameterizations are carried out using the enSuite software.

### CONTENTS

- Fundamentals of volume conversion
- Metrological use of volume converters
- Short introduction of volume converter EK280/EK220/EK205
- Connecting components for remote data transfer
- User interface of the devices
- Interpreting and acknowledging error messages
- Battery change
- enSuite parameterization software
- Reading and visualization of process and archive data

### NOTES

Optional, further content on request

### TARGET GROUP

Fitters from grid or meter operators. Personnel from the field of remote meter reading and billing who wish to obtain an overview of the electronic metering technology used.

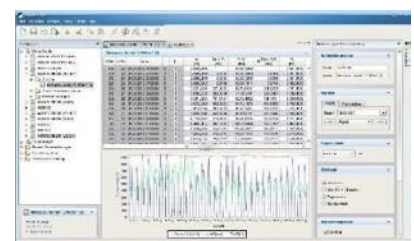



## Ultrasonic flow metering

TRAINING ON REQUEST

## USM 1

### AIM

In this 3-days seminar, participants get to know the functions and possible applications of Q.Sonic Gas Flowmeters and learn how to perform commissioning, function checks, maintenance, hardware and firmware upgrade and troubleshooting of series 6 Q.Sonic flow meter.

### CONTENTS

- Fundamental and principal of an ultrasonic metering
- Design and Structure of NGQ & Legacy ultrasonic flow meter
- Ultrasonic configuration software
- Commissioning & best practices
- Data analysis
- Troubleshooting and fault analysis
- Optimization of USM setting and tolls to use
- Firmware and hardware upgrade
- Series 6 electronic retrofit kit upgrade on legacy meter
- Configuration of an old meter

### NOTES

- Safety footwear is required
- A laptop with administrations rights is required (installation of the current Sonic explorer & enSuite softwares)

### TARGET GROUP

- Service technicians
- Measurement engineer
- Technical specialist

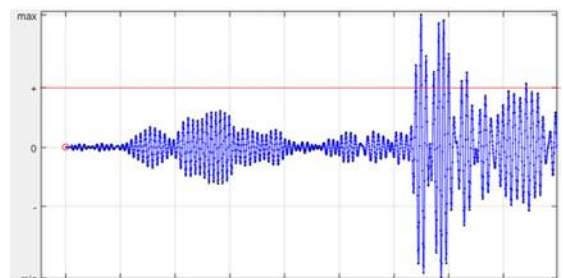



## Ultrasonic flow metering

TRAINING ON REQUEST

## USM 2 (EXPERIENCED USERS)

### AIM

This 2-days seminar is intended for experience service technicians and auditors who carry out or assist tests, function checks, perform maintenance, hardware and firmware upgrade and troubleshoot of the ultrasonic flow meter.

Enable experience field personnel to perform service electronic Series VI retrofit upgrade kit, be able to analyze data and troubleshoot fault analysis on the device during commissioning.

### CONTENT

- Fundamental and principal of an ultrasonic metering
- Design and Structure of & Legacy ultrasonic flow meter
- Series -VI Configuration (Uniform data conversion Sonic Explorer or enSuite)
- Electronic hardware upgrade from Series-III or IV to Series-VI
- Commissioning & best practices
- Data analysis, Optimization of USM setting and tools to be used
- Troubleshooting and fault analysis
- Firmware and hardware upgrade

### NOTES

- Safety footwear is required
- A laptop with administrations rights is required (installation of the current Sonic explorer & enSuite softwares)

### TARGET GROUP

- Service technicians
- Measurement engineer
- Technical specialist

### PRECONDITION

Participation in USM I seminar and experience in Q.Sonic trouble shooting





## Condition Based Monitoring (CBM)

**TRAINING ON REQUEST**

## MEASUREMENT-IQ FOR GAS

### AIM

In this 1-day seminar, participants get to know the functions and applications of MIQ and learn how to configure and perform data evaluation. You will be able to leverage the Power of Connected, to use MIQ's real-time, round-the-clock CBM to cut the costs of lost and unaccounted for gas, anticipate problems before they occur while keeping the measurement uncertainty to a minimum.

### CONTENTS

- Introduction: Architecture and functions
- Design and interface of MIQ
- Setting of parameters
- Communication setup
- Reference setup
- Maintenance and Diagnostic

### TARGET GROUP

- Service technicians
- Metering engineers







## Industrial Gas Stations

# INDUSTRIAL GAS FLOW COMPUTER ENCORE FC1

### AIM

In this 2-day seminar, participants learn the application and configuration options of enCore FC1 Flowcomputers with integrated registration.

Parameterizations are carried out using the enSuite software in the so-called “normal mode”.

Comprehensive practical exercises are intended to facilitate use of the enCore FC1 with different I/O process connections and various components and simulations.

New developments and regulations are currently being communicated.

### CONTENTS

- Introduction, overview and features of network connection
- Functioning of the FC1
- Online/Offline parameterization
- Application and parameterization of FC1
- Installation and use of the enSuite software

### NOTES

It is a good idea to bring a notebook laptop with administrator rights to install the most recent parameterization software (enSuite)

On request, we can cover the applications in „expert mode“ in specially designed seminars.

### TARGET GROUP

Users who are already familiar with volume conversion devices and who wish to use the enCore FC1 in the future.

### PRICE per participant for classroom in Dortmund

1510 € plus VAT

### SCHEDULE

Day 1 09:00 - 16:30

Day 2 08:30 - 16:00

### TRAINING ON REQUEST

#### Scheduled DATES in Dortmund

11./12.06.2025

19./20.11.2025

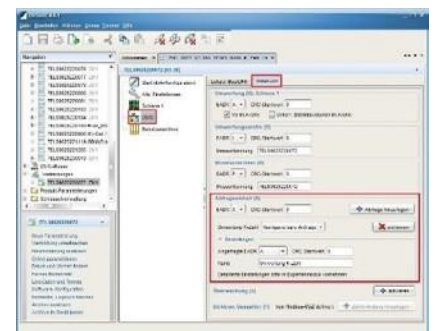



**Natural Gas, What is the composition and calorific value?**

**TRAINING ON REQUEST**

## **GAS QUALITY ANALYZER ENCAL3000**

### **AIM**

In this 2-day seminar, participants get to know the functions and possible applications of EnCal3000 Gas Analyzers and learn how to independently evaluate chromatograms and a how to perform a basic calibration and an error analysis to be prepared for support of official calibration measures and to independently optimize processes and analyze errors.

### **CONTENTS**

- Design and type of action of PGC EnCal3000 natural gas and biogas
- Design and structure of the RGC3000 application software
- Operating the gas-net EnCal3000 evaluation unit
- Setting of parameters
- Carrying out a calibration
- Connecting and measuring test gases
- Connecting the evaluation unit
- Questions and ideas

### **NOTES**

Safety footwear and a laptop with administrator rights are required (installation of the parameterization software).

### **TARGET GROUP**

Service technicians and auditors who carry out tests and function checks of the EnCal 3000.

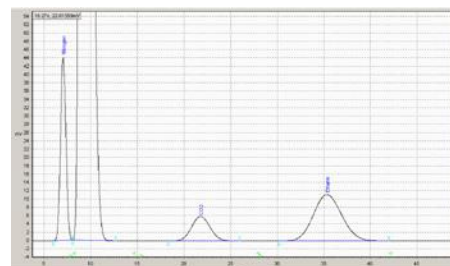



**Natural Gas, What is the composition and calorific value?**

## **GAS QUALITY ANALYZER ENCAL PROCHAIN**

### **AIM**

In this 2-day seminar, participants get to know the functions and possible applications of EnCal3000 prochain Gas Analyzers and learn how to evaluate chromatograms and how to perform a basic calibration and an error analysis. So you are prepared to support official calibration measures and to independently optimize your processes and analyze errors.

### **CONTENTS**

- Design and type of action of EnCal3000 proChain for natural gas C6
- Design and structure of the enSuite parameterization software
- Setting of parameters
- Carrying out a calibration
- Connecting and measuring test gases
- Connecting the evaluation unit
- Questions and ideas

### **NOTES**

Safety footwear and a laptop with administrator rights are required (installation of the enSuite software).

### **TARGET GROUP**

Service technicians and auditors who carry out tests and function checks of the EnCal3000 proChain.

### **PRICE per participant for prescheduled classroom in Dortmund**

1890 € plus VAT.

### **SCHEDULE**

Day 1 09:00 - 16:30

Day 2 08:30 - 16:00

**TRAINING ON REQUEST**

**Scheduled DATES  
in Dortmund**

05./06.03.2025 (English)

16./17.09.2025 (German)

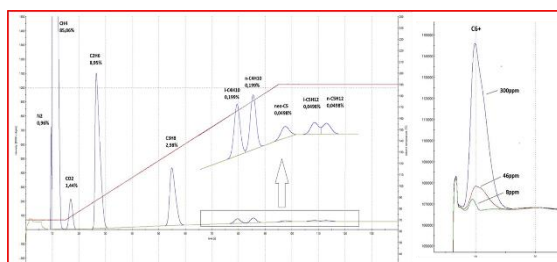



**Natural Gas, What is the calorific value? Fast Analysis**

## **GASLAB Q2 SEMINAR**

This one-day seminar is intended for service technicians and auditors who carry out or assist tests and function checks of the Gas-Lab Q2.

### **AIM**

Evaluation of process values, carrying out service calibration, test gas analyses runs, fault analysis on the device.

### **CONTENTS**

- Design and type of action of Gas-Lab Q2
- Design and structure of the Q2 application software enSuite
- Evaluation of source values
- Operating the Q2 display unit
- Setting of parameters
- Carrying out a calibration
- Connecting and measuring test gases
- Connecting the evaluation unit
- Troubleshooting

### **NOTES**

Safety footwear is required

A laptop with administrations rights is required (installation of the current enSuite software)

### **TARGET GROUP**

Service technician.

### **PRICE per participant for prescheduled classroom in Dortmund**

950 € plus VAT. (can be booked together with Enal3000 proChain-Seminar the days before)

### **SCHEDULE**

Day 3 08:30 - 16:00

**TRAINING ON REQUEST**

**Scheduled DATES  
in Dortmund**

07.03.2025 (English)

18.09.2025 (German)

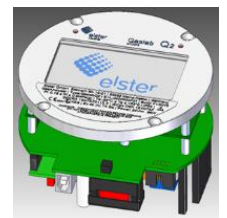



**No Time to Come to Us?**

## **ON-SITE SEMINARS**

We can also organize a seminar specifically for your needs.  
We offer a wide range of topics in the following fields:

### **GAS METERS**

Diaphragm meters, rotary meters, turbine meters, indexes, interfaces, commissioning, operation of meters, fundamentals and practical exercises on section models.

### **COMPACT ELECTRONIC VOLUME CONVERTERS, FLOW COMPUTERS, GAS ANALYZERS, ULTRASONIC METERS**

Functions and applications of the devices (operation, setting values, error determination, archive readout), system connection (working with the enSuite parameterization software) and exercises directly on the devices

We can also combine content of different seminars in an individual offer for you

### **PRICE**

On Request

### **Contact:**

Paul Schamari via

[Elster.customer.trainings@honeywell.com](mailto:Elster.customer.trainings@honeywell.com)



## HOW TO FIND US



### MAINZ-KASTEL

The following seminars will be held at the seminar center in Mainz-Kastel:

- Industrial Gas Metering
- Basics of Volume Conversion Devices EK2x0
- Ultrasonic Flow meters
- Measurement IQ

#### Elster GmbH

Steinern Straße 19-21  
55252 Mainz-Kastel  
Germany

#### Information for Navigation Systems

Mainz-Kastel is a suburb of Wiesbaden in the Federal state of Hessen.



### DORTMUND

The following seminars will be held at the seminar center in Dortmund:

- Industrial Gas Flow Computer enCore FC1
- Gas Quality Analyzer EnCal 3000, EnCal3000 proChain
- Gaslab Q2

#### Elster GmbH

Schloßstraße 95a  
44357 Dortmund  
Germany



## REGISTRATION & ORGANIZATION

### REGISTRATION

You can register by contacting your local representative or send an e-mail to [elster.customer.trainings@honeywell.com](mailto:elster.customer.trainings@honeywell.com)

After aligning the details, you will receive a training agenda and all the information you need to book the training.

After booking we finally confirm the schedule and the order.

### OUR SERVICES

- Experienced trainers
- Training material
- Lunch on all training days
- Refreshments during the seminar
- Dinner with trainers on the first day for trainings booked for 2 and more training days

### HOTEL

In principle, you can book any hotel for seminars in our seminar rooms.

For the evening event, we select a restaurant in Mainz for seminars at the Mainz-Kastel location, so it is advisable to select a hotel that is within walking distance of Mainz city center.

For seminars in Mainz-Kastel, we have received predominantly positive feedback from our participants about the following hotels:

Hotel Mainzer Hof, Mercure Hotel Mainz City Center, Best Western Hotel

For seminars at our Dortmund location, participants receive a discount on the overnight price at the EuroStar-Hotel in Castrop-Rauxel. When ordering, please inform the hotel that you are a Honeywell-Elster customer.

### NO-SHOW and CANCELTION

If you have registered for a seminar that you cannot attend in person, you are welcome to send a colleague as a substitute. Please register your substitute by email to Jeannette Berrens before the seminar date (with name and email address).

In the event of a short-term cancellation, less than two weeks before the seminar date, or in the event of a no-show, we reserve the right to charge the full course fee if we cannot find another participant at short notice.

### YOUR CONTACT



**Jeannette Berrens**  
Trainings Assistant  
[jeannette.berrens@honeywell.com](mailto:jeannette.berrens@honeywell.com)

**Elster GmbH**  
Steinern Straße 19-21  
55252 Mainz-Kastel Germany

<https://process.honeywell.com/us/en/site/elster-instromet/training>